

BREAKING COMPUTATIONAL BARRIERS

THE CRAY C916 SUPERCOMPUTER SYSTEM



The CRAY C916 system is the most powerful, general-purpose supercomputer available for science and engineering applications. As the most parallel, highest-bandwidth vector supercomputer ever built, the CRAY C916 system breaks computational barriers with unmatched problem-solving capabilities.

The CRAY C916 system features a CRAY Y-MP compatible CPU with a peak performance of 1 billion floating point operations per second (1 GFLOPS). With up to 16 of these powerful processors, the CRAY C916 system delivers a peak performance of 16 GFLOPS.

Increased memory capacity

The CRAY C916 is an enhanced version of the original CRAY Y-MP C90 system. It provides new problem solving capabilities with up to 1 Gword (8 Gbytes) of central memory—four times the central memory capacity of the original CRAY Y-MP C90 system.

MPP ready

The CRAY C916 system can be closely coupled to the massively parallel CRAY T3D system. For highly parallel applications, this heterogeneous architecture makes an unprecedented level of performance accessible to a broad spectrum of users.

The optimal balance for high performance

The CRAY C916 supercomputer uses a balanced architecture to deliver the maximum amount of compute power to the user. To sustain the unmatched levels of throughput, its vector and scalar performance is supported by the highest memory, I/O, and SSD bandwidth available in any computer system.

Delivering supercomputing performance and user productivity through advanced software

To ensure that your applications take full advantage of CRAY C916 system performance, Cray Research provides the UNICOS operating system and associated system software products. UNICOS is a standard UNIX environment that has been enhanced to provide efficient parallel processing, production quality resource management, security, and network connectivity. User productivity is enhanced through the use of visual interfaces, advanced application-building tools, expert performance analysis tools, and automatic optimizing compilers.

The CRAY C916 computer system is upwardly compatible with CRAY Y-MP systems and features an enhanced instruction set that can lead to even higher levels of performance for applications compiled on the system. The CRAY C916 system also supports all current Cray Research disk drives, disk arrays, and a variety of tape storage devices.



CRAY C916 highlights

- ❑ Full upward compatibility with entire CRAY Y-MP line
- ❑ 8 or 16 CPUs
- ❑ Up to 16 GFLOPS peak performance
- ❑ MPP ready
- ❑ 128 - 1024 Mwords (1 - 8 Gbytes) central memory
- ❑ Four parallel memory ports per processor
- ❑ Memory bandwidth of up to 245.8 Gbytes/s
- ❑ 2 - 16 I/O clusters
- ❑ Up to 16 channel adapters per cluster for a total of 256 channels
- ❑ Aggregate I/O bandwidth of 13.6 Gbytes/s
- ❑ Optional SSD with 512 - 4096 Mwords (4 - 32 Gbytes)
- ❑ UNICOS operating system based on UNIX System V

Applications

The CRAY C916 system supports the complete CRAY Y-MP library of leading-edge applications for nearly every scientific and engineering discipline. Commercial industries, such as aerospace, automotive, chemical, pharmaceutical, electronics, energy, and petroleum use these applications to accelerate product development, increase productivity, and solve basic research problems.

Field upgradable

The CRAY C916 computer system is field upgradable. The standard configuration CRAY C916 system includes eight CPUs, 128 Mwords of central memory, and two I/O clusters with 15 channel adapters (DCA-1, DCA-2, TCA-1, and CCA-1). Upgrade options include additional central processing units, I/O clusters, central memory capacity, and an optional SSD.

Physical description

The CRAY C916 system comprises a mainframe cabinet and an IOS cabinet. The mainframe cabinet contains the CPUs, central memory, and power supplies. The IOS cabinet contains the I/O subsystem and optional SSD.

CRAY C916 product specifications

CPU

Technology	Custom silicon 10,000 gate array circuits
Number of CPUs	8 or 16
Vector pipes	2 per CPU
Peak performance	16 GFLOPS

Memory

Memory ports	4 double-word ports per CPU
Technology	15 ns BiCMOS
Memory size	128, 256, 512, or 1024 Mwords (1, 2, 4, or 8 Gbytes)
Maximum memory bandwidth	245.8 Gbytes/s

I/O

Number of I/O clusters	1 - 16
I/O bandwidth	13.6 Gbytes/s
HIPPI channels	100 or 200 Mbytes/s
LOSP channels	8 - 16@12 Mbytes/s
HISP channels	8 - 16@200 Mbytes/s
VHISP channels	1 - 4@1800 Mbytes/s

Optional SSD

Capacity	512, 1024, 2048, or 4096 Mwords (4, 8, 16, or 32 Gbytes)
Bandwidth	13.6 Gbytes/s

Physical characteristics

Mainframe cabinet footprint area	48 ft ² (4.5 m ²)
IOS/SSD cabinet footprint area	21 ft ² (2.0 m ²)
Cooling equipment area	50 ft ² (4.6 m ²) †

† 50 Hz installations may require additional support equipment.

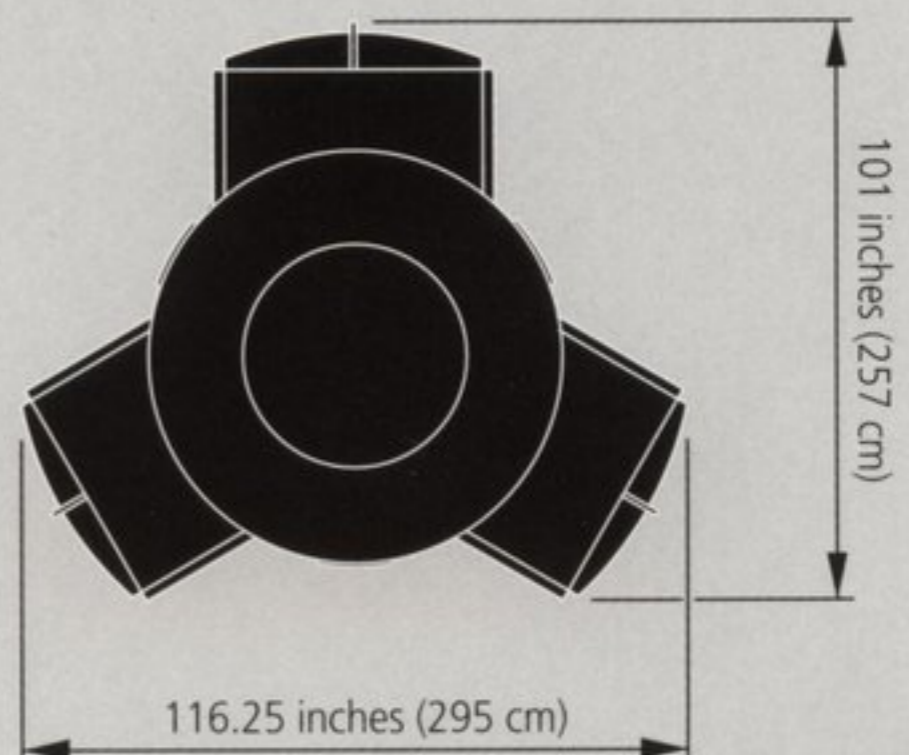

CRAY, CRAY Y-MP, and UNICOS are federally registered trademarks, and CRAY C916 and CRAY T3D are trademarks of Cray Research, Inc. UNIX is a trademark of UNIX System Laboratories, Inc. Product specifications and the availability of the products are subject to change without notice. For the latest information, contact your Cray Research representative.